

Product Specification



QZ-CK01/A0(D) 3 Stage Heated Seat Pads



KEY FEATURES

- 2 pad heated seat elements
- 2 pads per seat
- 3 stage variable heat settings
- Carbon fibre design
- Max temp 70C
- 50W max power consumption
- Dimensions 450 x 280 x 0.3mm
- EMC compliant, approved by TUV
- EMark E24 certified
- Current draw: High 2.278 A, Medium 1.646 A, Low 1.155 A, Off 1.011 A

FOR MORE INFORMATION, CONTACT OUR SALES TEAM.

T: 020 8863 8333 (OPT1) • **E:** sales@c-ko.co.uk • **W:** www.c-ko.co.uk

Product Specification

3 Stage Heated Seat Pads

Installation Information

Please read through the following instructions carefully before installation.

Warnings:

1. Never fold the pad on itself.
2. Never cut the pad lengthways. If you need two halves, please use the 4 pad version.
3. Never run the heated seats without running the engine as this will flatten the battery.
4. Never put hot or sharp objects on the pad.
5. Please be aware of cars with side airbags. The company will not take responsibility if an airbag erupts.

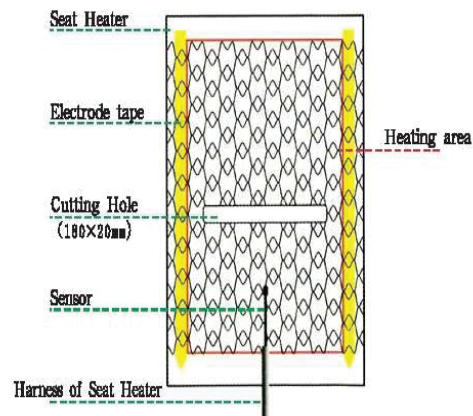
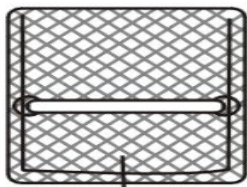

Fig.1 Structure of Carbon Fibre Heating Pad

Cutting the Pad

1. If you need to cut a hole in the pad, the maximum size hole is 180mm by 20mm (see pic.1 for details). This should leave 25mm between the hole and the electrode tape.
2. You can only cut the pad horizontally, it can not be cut vertically.
3. Be careful not to damage the electrodes, as this will cause the heated seat to malfunction.
4. If the pad is too long, you can cut up to 1/3 (150mm) off the side opposite the wiring harness. Do not exceed this amount. Insulate the cut edges well.

Hole is longer than 180mm



Hole is taller than 20mm

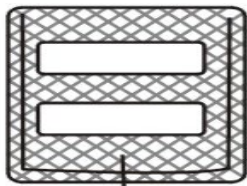

Hole is too close to the sensor in the heating pad

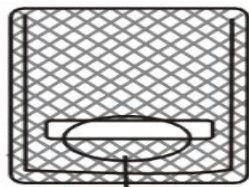

Electrode line has been cut

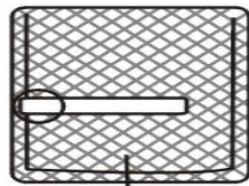

Holes have been cut vertically

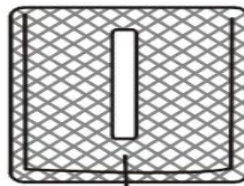
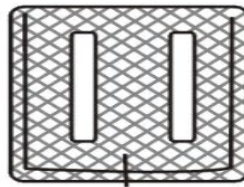

Possible affects of poor installation



No installation on the edges of the seat heater

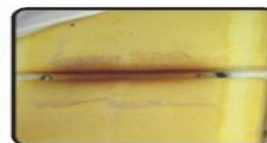

Haven't cut the heated seat correctly

FOR MORE INFORMATION, CONTACT OUR SALES TEAM.

T: 020 8863 8333 (OPT1) • **E:** sales@c-ko.co.uk • **W:** www.c-ko.co.uk

Product Specification



3 Stage Heated Seat Pads

Installation Information

Installation Steps:

1. First, start by removing the seat from the vehicle and placing it on a suitable work bench. Remove the upholstery from the seat and lay the pad on to confirm the position. If it needs cutting (please refer to 'cutting the pad' for correct cutting method).
2. Fully insulate any metal frame using PVC tape to avoid causing a short. Lay the pad with the adhesive side facing the foam. Use the hog rings supplied to hold pad and metal frame down.

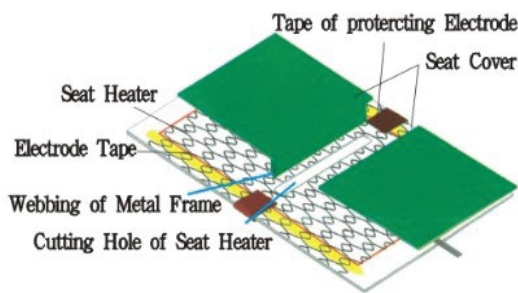

Pic.2 Cut hole & Tape of Protecting Electrode

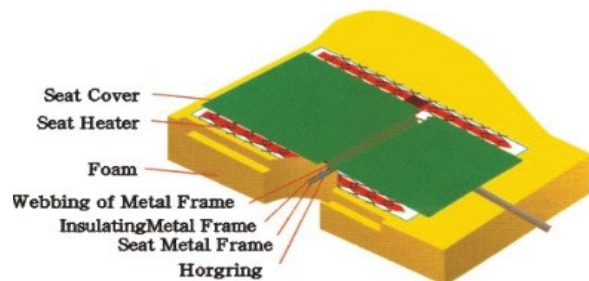

Pic.3 Metal Frame disposal

3. Remove the covering paper and thoroughly glue the edges of the pad to the foam. Run the cable to a convenient position below the seat.
4. Seat may now be recovered with the upholstery.
5. Always use the fuse assembly provided with the wiring harness in order to protect the circuits. If the fuse blows, only replace it with a 10A fuse.
6. Before installation of the wiring, remove the negative terminal of the battery to prevent any chance of a short.
7. It is recommend you run the power lead to the vehicles fuse box. Use a circuit which is only on when the ignition is on. Failure to do so will drain the battery if the seat heater is left on while the engine is not running.

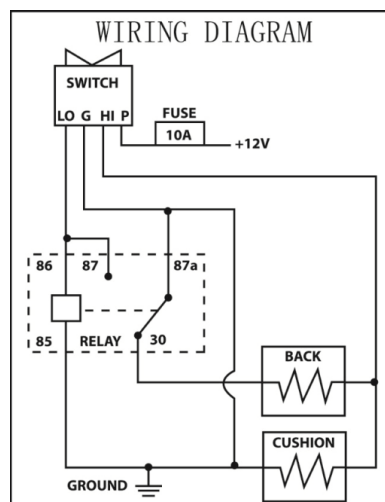

FOR MORE INFORMATION, CONTACT OUR SALES TEAM.

T: 020 8863 8333 (OPT1) • **E:** sales@c-ko.co.uk • **W:** www.c-ko.co.uk

Product Specification



3 Stage Heated Seat Pads

Installation Information

Installation Steps:

8. Ground the wiring harness on a suitable location on the car chassis. If needed, remove a little bit of paint to give the best possible connection.
9. The switch may now be installed in the vehicle dash, centre console or plastic of the seat. You will need to use a 20mm hole cutter to make the correct size hole.
10. Plan the location of the switch carefully. Consider ease of access for the vehicle occupant/s and for routing the wires safely. Check for wiring harnesses, ducting, structural parts and obstructions behind where you are drilling.
11. The seat may now be returned to the car. Reconnect the battery and test the heated seat is functioning correctly.

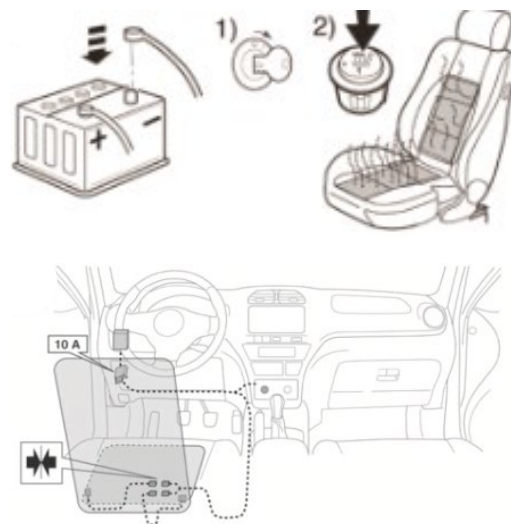

Troubleshooting

No.	Fault	Possible Cause(s)
1	No light on switch, system does not work	Check all power connections
2	Light on, system does not work	Check main power lead, fuse
3	Light on, pads not heating up	Check ignition wire
4	Light on, a certain seat is not hot	Check heat controller, heating pad
5	Light on, seat is not hot enough	Check heat controller, heating pad
6	Light on, seat is too hot	Check heat controller, heating pad
7	After powering up fuse keeps blowing	Check wiring for no short circuits, heat controller

FOR MORE INFORMATION, CONTACT OUR SALES TEAM.

T: 020 8863 8333 (OPT1) • **E:** sales@c-ko.co.uk • **W:** www.c-ko.co.uk