

Product Specification



CKO-LED-211-M-A Amber Beacon 8 LED Magnetic Mount



CKO-LED-211-M-A

KEY FEATURES

- Lens: Amber
- Fixing: Magnetic Mount
- Approval: ECE R10 / R65
- Voltage: 9-30v
- IP Rating: IP67
- LEDs: 8
- Patterns: 4 Selectable Flash Patterns
- Dimensions: 118mm x 154mm
- Flash pattern programming via push button under lens
- Cigarette lighter power attachment
- Polycarbonate lens
- -30° to +60° operating temperature

FOR MORE INFORMATION, CONTACT OUR SALES TEAM.

T: 020 8863 8333 (OPT1) • **E:** sales@c-ko.co.uk • **W:** www.c-ko.co.uk



Product Specification

Amber Beacon 8 LED Magnetic Mount

Product Dimensions Diagram

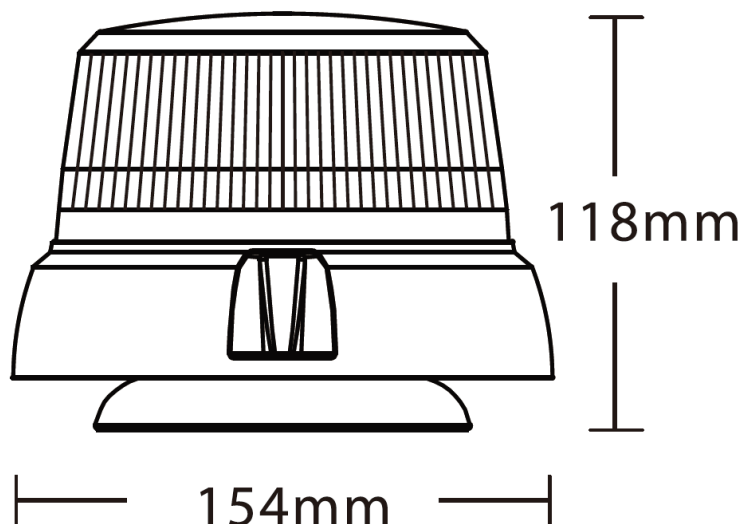

Wiring Information

- **Red:** Power
- **Black:** Ground



Warning: Avoid looking directly at LEDs while they are in operation. Doing so may result in temporary vision impairment or permanent eye damage.

It is not recommended to use magnetically mounted warning devices on vehicles as a permanent addition, magnetically mounted warning devices are designed for temporary usage. The device may become dislodged while the vehicle is moving at speed, posing a risk of damage to the vehicle or injury to people nearby.

FOR MORE INFORMATION, CONTACT OUR SALES TEAM.

T: 020 8863 8333 (OPT1) • **E:** sales@c-ko.co.uk • **W:** www.c-ko.co.uk